



## The sabbar group

The **sabbar** Group commenced its journey in the year 1975, when sabbar started its first unit for the manufacture of water pumps. Unbounded passion, unmatched skill & uncompromising quality control led the group from one success to another. The certification of ISO 9001, 14001, CE and ISI marks were just an affirmation that sabbar is the signature of Quality. sabbar has passed through prestigious third party inspection conducted by EIL, PDIL, DGS&D, RITES, EIA, INSPECTORATE, SGS to name a few.

The path to progress has been marked by many milestones wherein consolidation and diversification have been the mantra. The foray into export market confirmed the global vision of the company.

The Group's uncompromising commitment to quality, customer satisfaction, adoption of latest technologies, inclusion of new types and developing standard products through continuous R&D yielded magnificent results.

The AC Electric Motor manufactured by sabbar Engineering Pvt. Ltd. comes to the customer with the prestigious International Quality certification IS / ISO 9001 from TUV NABCB Certification Body. Our Group Company, sabbar Pumps Pvt. Ltd., also has international quality certification ISO 9001 from the Bureau of India Standards (accredited by Raad voor de Certificate, Netherlands) and another group company, India Electrical & Engineering Company, also has international quality certification ISO 9001 from BVQI London.

Presently, there are 8 companies in the sabbar Group involved in manufacturing, marketing and export of different types of pumps, motors & other engineering products. sabbar Group has an all-India presence through 14 marketing offices and a 1500 strong dealer network in all important cities. sabbar products are exported to more than 33 countries around the world.

sabbar Export, the export division of sabbar Group, has received the prestigious "National Award for the Export Excellence" from Engineering Export Promotion Council (EEPC) under the Ministry of Commerce, Government of India. We have also won the "Star Performer Award" 13 times, from EEPC for the western region.

Manufactured By

Distributor / Dealer

**sabbar Engineering Pvt. Limited**

A2/3912, G.I.D.C. Estate, Phase 4, Vatva, Ahmedabad-382 445 (INDIA)  
Tel : (+91 79) 25840213, 25840261 Fax : (+91 79) 25840289  
E-mail : marketing@sabarelectricmotors.com  
Web site : sabarelectricmotors.com

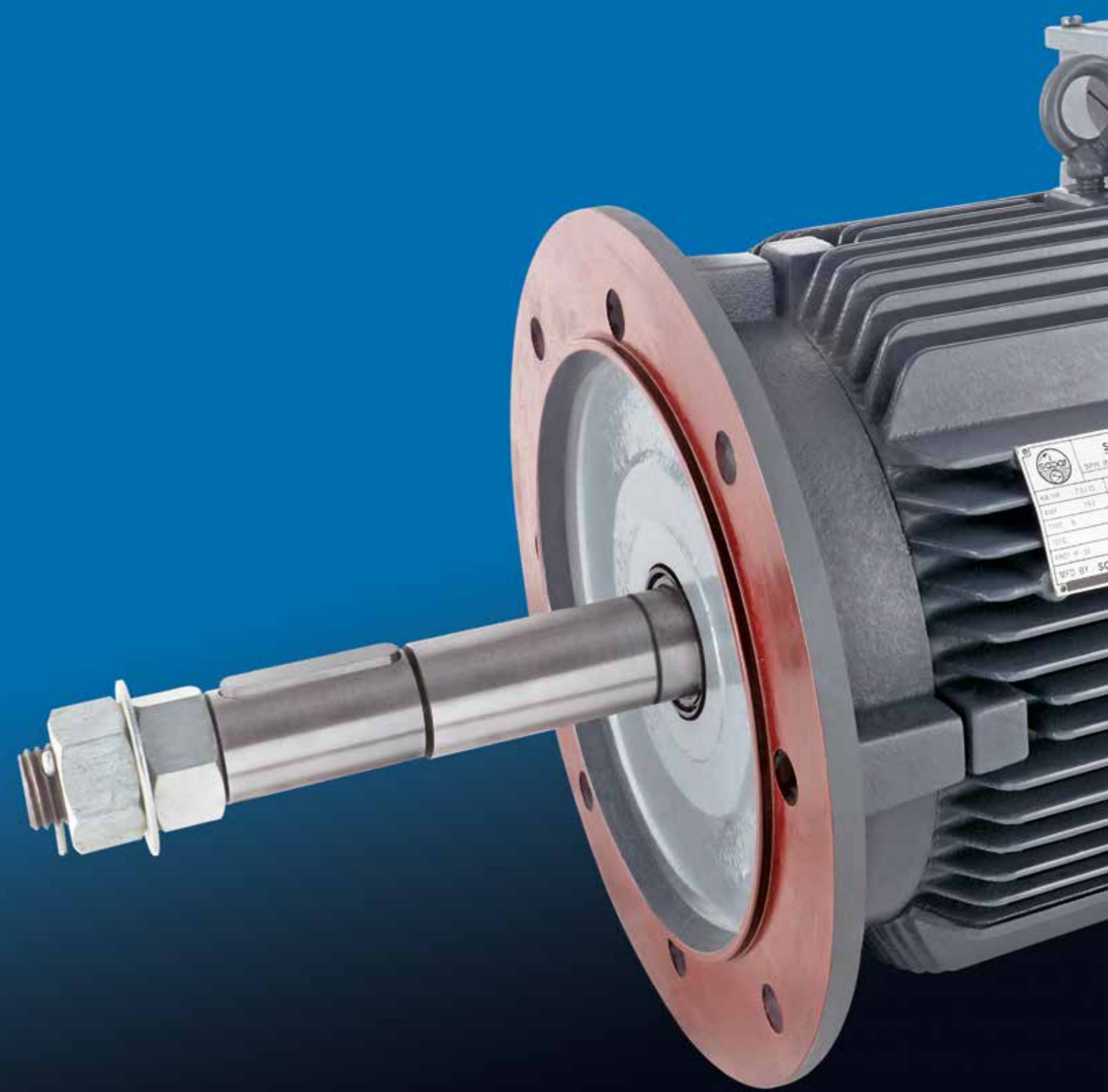

**sabbar**  
Three Phase Cooling Tower Motors



A product from Sabar Group (Established since 1975)  
**THREE PHASE COOLING TOWER MOTORS ELECTRICAL & MECHANICAL DATA**



- RANGE :**  
 Standard 3 Phase Cooling Tower Motors with rating 0.18 KW to 30.0 KW are available from frame size 63 F to 225 F with Standard Speeds.
- STANDARDS :**  
 Performance conforms to IS:325:1996.
- RATINGS :**  
 Motors are rated for continuous duty type S1 at an ambient of 45 Deg. C and site altitudes of upto 1000 M above mean sea level.
- VOLTAGE AND FREQUENCY :**  
 Motors designed are for a rated voltage of 415 V +/- 10%, 3 Phase, 50 Hz +/- 5% supply. Motors with special designs of Voltage/Frequency can be offered on request.
- PAINT :**  
 Cooling Tower Motors are provided with EPOXY paint to ensure long life of external surface.
- CONSTRUCTION :**  
 Cooling Tower Motors are specially designed flange mounted in totally enclosed constructions.
- INSULATION SYSTEM :**  
 All Cooling Tower Motors are provided with class "F" insulation system.
- DEGREE OF PROTECTION :**  
 All Cooling Tower Motors are having IP 55 Protection to avoid water ingress.
- TERMINAL BOX :**  
 All Cooling Tower Motors are provided with terminal box on the top front as seen from the non-drive end.
- NOISE :**  
 Motors are designed for low noise level in accordance with IS 12065.
- BEARING SYSTEM :**  
 All Motors having double shielded ball bearings.
- EARTHING TERMINALS :**  
 Earthing Terminals are provided on the stator housing or in Terminal Box in all motors.
- MATERIAL OF CONSTRUCTION :**  
 All Cooling Tower Motors are in CI material.

Due to continuous Research & Development, design and specifications are subject to change without notice.



**Dimension of Cooling Tower Motor (B 5 Construction)**

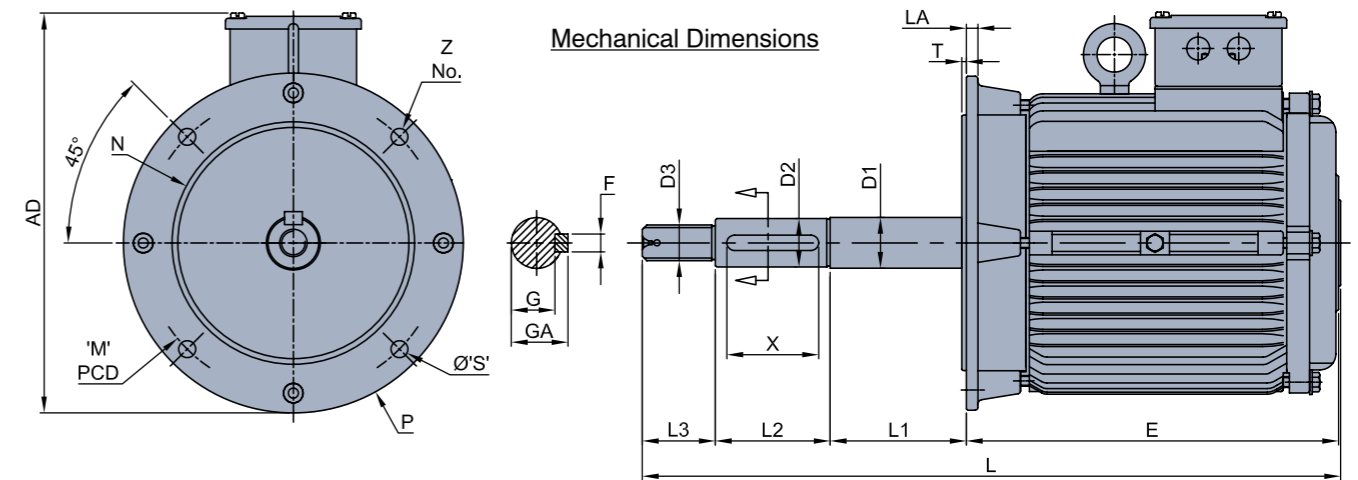

#All Dimensions are in M.M.

FRAME	D1	D2	D3	G	GA	L	L1	L2	L3	E	F	P	'M'	N	'S'	Z	T	LA	X	AD
63	12	11	M10	8.5	12.5	24.5	35.5	25	30	155	4	140	115	95	10	4	3	9	20	185
71	15	14	M12	11	16	278	40	30	30	178	5	160	130	110	10	4	3.5	9	25	195
80	20	19	M16	15.5	21.5	347	55	50	45	197	6	200	165	130	12	4	3.5	10	35	224
90S	30	28	M24	24	31	459	112	55	60	232	8	200	165	130	12	4	3.5	11	45	232
90L	30	28	M24	24	31	484	112	55	60	257	8	200	165	130	12	4	3.5	11	45	232
100L	30	28	M24	24	31	486	112	55	60	259	8	250	215	180	15	4	4	11	45	285
112M	30	28	M24	24	31	505	112	55	60	278	8	250	215	180	15	4	4	11	45	296
112-132	40	38	M30	33	41	508	90	75	65	278	10	300	265	230	15	4	4	13	70	292
132S	40	38	M30	33	41	535	90	75	65	305	10	300	265	230	15	4	4	13	70	338
132M	40	38	M30	33	41	573	90	75	65	343	10	300	265	230	15	4	4	13	70	338
132-160	45	42	M30	37	45	573	90	75	65	343	12	350	300	250	19	4	5	15	65	336
160M	45	42	M30	37	45	644	90	75	65	414	12	350	300	250	19	4	5	15	65	395
160L	45	42	M30	37	45	688	90	75	65	458	12	350	300	250	19	4	5	15	65	395
180L	50	48	M30	42.5	51.5	811	100	105	65	541	14	350	300	250	19	4	5	15	100	430
200L	60	55	M30	49	59	835	100	105	69	561	16	400	350	300	19	4	5	16	100	480
225S & M	65	60	M30	54	64	879	100	130	69	580	16	450	400	350	19	8	5	20	100	540

\*All figure are subject to tolerance as per IS:325:1996 | Design and specification are subject to change without prior notice

**Product Range**

Power	0.25 Hp to 40 Hp (0.18kw to 30 kw)
Frame Size	63 F to 225 M
Voltage	415 V ± 10% or as required
Insulation	Class 'F'
Type of Duty	S1
Ambient Temp.	45° cel.

Polarity	4P, 6P, 8P, 10P, 12P
Mounting	Flange mounted (B5)
Frequency	50 Hz ± 5% or as require
Protection	IP 55
Enclosure	Totally enclosed (TE)
Temp.rise	As per Insulation class 'B'